

CTI PXS-9102 Phase Locked Crystal Oscillator

Information compiled by Rex Allers, KK6MK

At the 2001 Microwave Update one of the vendors sold several frequency sources made by Communications Techniques Inc. (CTI). There was a generic data sheet that indicates they are low phase noise sources that lock to a 5 or 10 MHz reference input and generate an output frequency in the range 30 to 200 MHz.

The particular unit that I have was labeled as 95.5 MHz. The unit has 5 solder feed-through pins. One is the ground tab attached to the case. Two pins are for +15 V and +5 V power inputs. The two remaining pins are Alarm and Phase Lock outputs. It has 2 SMA connectors, one for Reference input and one for RF output. Figure 1 shows the unit.



Figure 1 - Outside of PXS Source

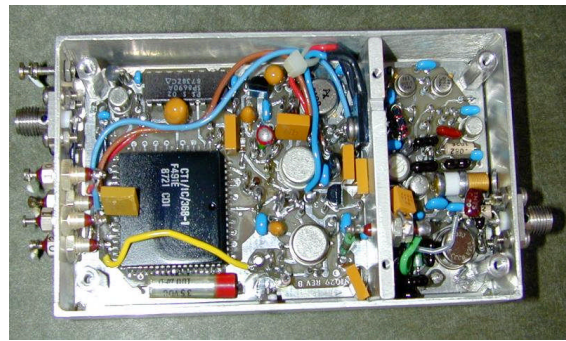

Figure 2 - Inside

Looking at the internals (Figure 2) the smaller section is the crystal oscillator for the output frequency. The oscillator uses an HC35 crystal (a TO-5 package). The digital phase lock circuit is implemented mainly in a custom ASIC.

By trial and error I determined that my 95.5 MHz unit would lock with a reference frequency of 1 MHz. The ALM pin gives an output of 0 V unlocked, and about 5 V when locked. The ϕ LOCK pin reflects the tuning voltage for the oscillator. It approximately ranges from 0 to 13 V. When locked to the reference this voltage should be adjusted near 5-6 V using the XTAL ADJ trimmer screw.

This is all fine, but I was hoping I could modify the unit for use with a 106.5 crystal and use a reference input of 10 MHz. The question was if the loop could be modified for use with different frequencies. With that many pins on the ASIC I suspected there might be jumpers for selecting counters. I decided to try to get to the bottom of the circuit board. By removing the output SMA, unsoldering the wires and removing many screws and standoffs, I was able to remove the board. There are 6 screws into the aluminum divider that must be removed. Two of these are under the label. Several screws have been installed with some form of Loctite so getting them out is not easy.

Looking at the bottom of the board (Figure 3) there are a series of cut traces around the ASIC. The control pins are connected to a +V and a Ground bus. Each of these pins must have a cut on either the +V or the Gnd trace to pull the pin up or down. There are 41 pins configured this way and a few others with cuts in a different pattern.

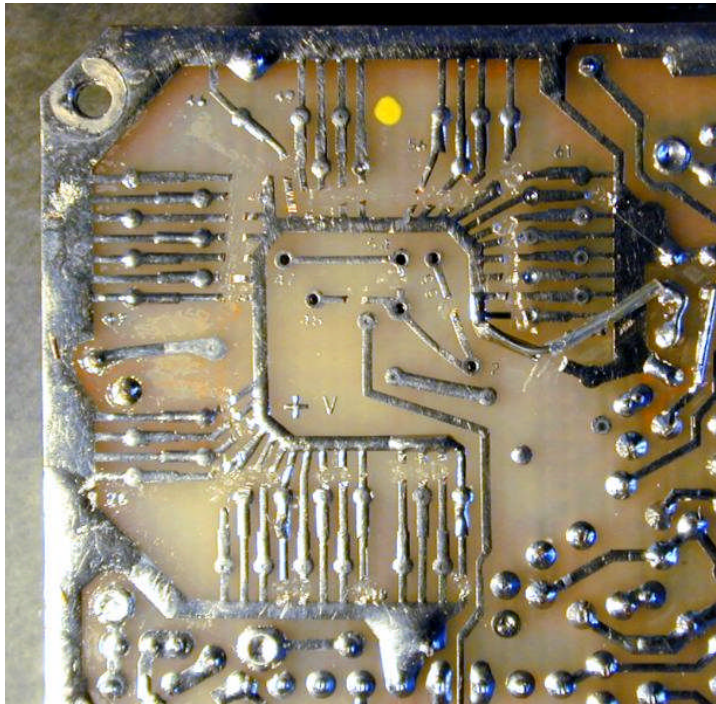

Figure 3 - Cuts on bottom of board

Working out how these cuts affect the counters by trial and error seemed like a formidable task. Fortunately, after a little polite begging, one of the engineers at CTI said he would try to provide me some information if he had time. After a few days I received a FAX and I believe this will provide enough information for hams who have obtained these sources to adapt a unit for a different frequency near 100 MHz. The example showed how to set the board for a frequency of 106.25 MHz and a reference of 10 MHz. After examining this example and comparing it with the settings for the original configuration of 95.5 MHz and 1 MHz reference, I think what I describe will be accurate. I don't have every detail, but I expect this will be enough information to convert a unit for a frequency near 100 MHz.

Setting for a different frequency

- 1) Choose your output frequency and reference frequency. You will need to replace the crystal with a new crystal at the output frequency (room temperature crystal).
- 2) Pick a phase detector frequency that is an integer factor of both the output and reference frequencies. This frequency should be near 500 KHz (assuming your unit is like mine) to avoid a need to change the loop filter.
- 3) Calculate the M and N counter values for your frequencies and make the appropriate cuts and jumpers on the bottom of the board.

Counter values

The M counter divides the oscillator frequency. The N counter divides the reference frequency. The pins that set these counters are in sub-groups such as M2, M1, N2 or N1 (details later). Here is an example for the original configuration of my unit:

Original 95.5 MHz settings

Output Frequency = 95.5 MHz

Reference Frequency = 1 MHz

Phase Detector (PD) Frequency = 500 KHz

VCXO Divider No. (M) = OUT / PD = 191

$M = (M2 \cdot 100) + (M1 \cdot 10) + A$; therefore, $M2 = 1$, $M1 = 9$, $A = 1$

REF Divider No. (N) = REF / PD = 2

$N = ((256 \cdot N3) + (16 \cdot N2) + N1) (REF1+1) (REF0+1)$

therefore, $REF0 = 0$, $REF1 = 0$, $N3 = 0$, $N2 = 0$, $N1 = 2$

I assume M5 M4 M3 are higher decades for the M value but in all examples I have seen, these are = 0

Jumper settings:

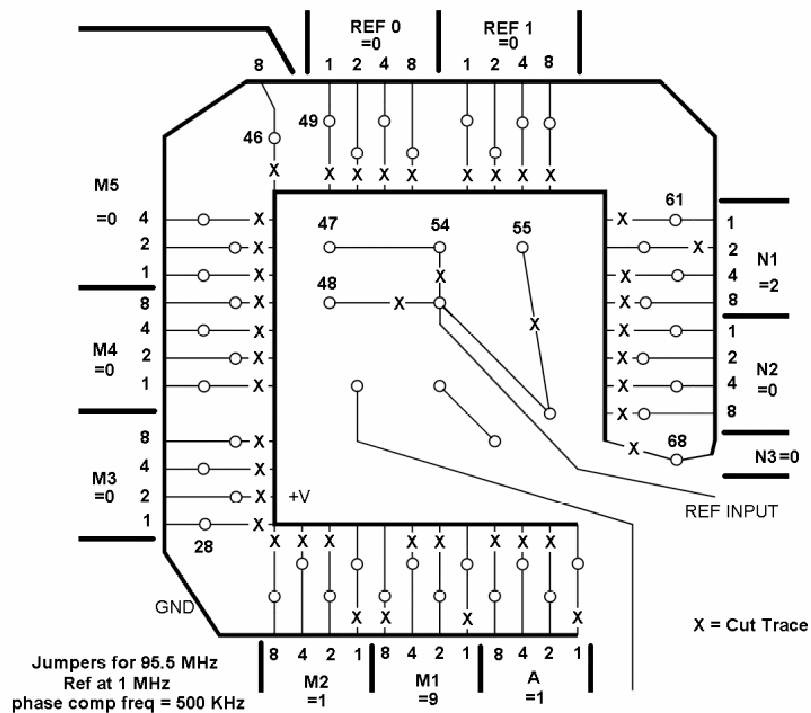

Figure 4 - Original Jumpers for 95.5 MHz Output and 1 MHz Ref

Example for 106.25 MHz and 10 MHz Ref

Output Frequency = 106.250 MHz

Reference Frequency = 10 MHz

Phase Detector (PD) Frequency = 625 KHz

VCXO Divider No. (M) = OUT / PD = 170

$M = (M2 \cdot 100) + (M1 \cdot 10) + A$; therefore, $M2 = 1$, $M1 = 7$, $A = 0$

REF Divider No. (N) = REF / PD = 16

$N = ((256 \cdot N3) + (16 \cdot N2) + N1) (REF1+1) (REF0+1)$

therefore, $REF0 = 0$, $REF1 = 0$, $N3 = 0$, $N2 = 1$, $N1 = 0$

I assume $M5$ $M4$ $M3$ are higher decades for the M value but in all examples I have seen, these are = 0

Jumper settings:

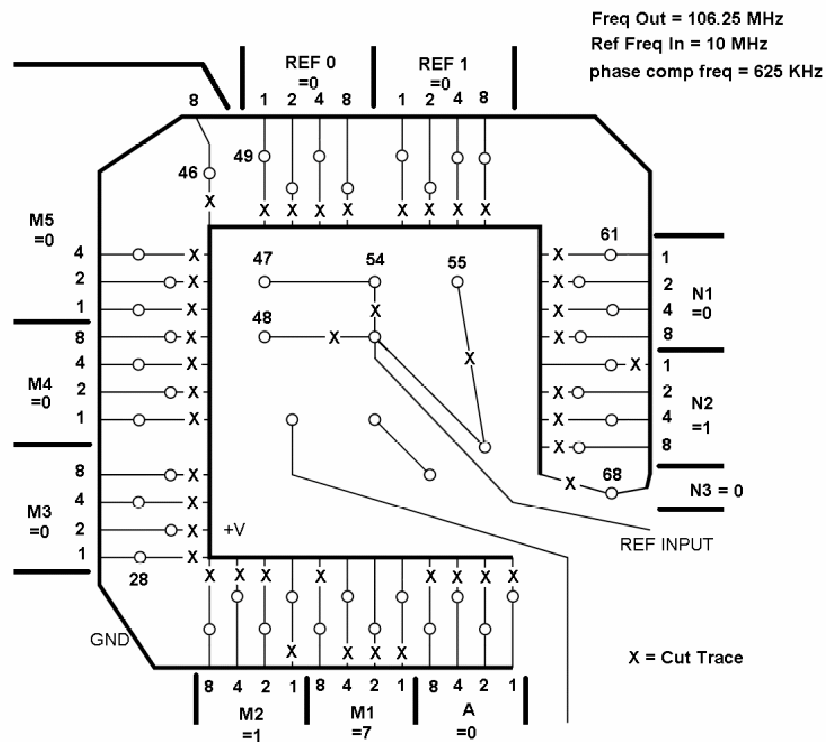

Figure 5 - Jumpers for 106.25 MHz Output and 10 MHz Ref

Example for 106.5 MHz and 10 MHz Ref

Output Frequency = 106.500 MHz

Reference Frequency = 10 MHz

Phase Detector (PD) Frequency = 500 KHz

VCXO Divider No. (M) = OUT / PD = 213

$M = (M2 \cdot 100) + (M1 \cdot 10) + A$; therefore, $M2 = 2$, $M1 = 1$, $A = 3$

REF Divider No. (N) = REF / PD = 20

$N = ((256 \cdot N3) + (16 \cdot N2) + N1) (REF1+1) (REF0+1)$

therefore, $REF0 = 0$, $REF1 = 0$, $N3 = 0$, $N2 = 1$, $N1 = 4$

I assume $M5$ $M4$ $M3$ are higher decades for the M value but in all examples I have seen, these are = 0

Jumper settings:

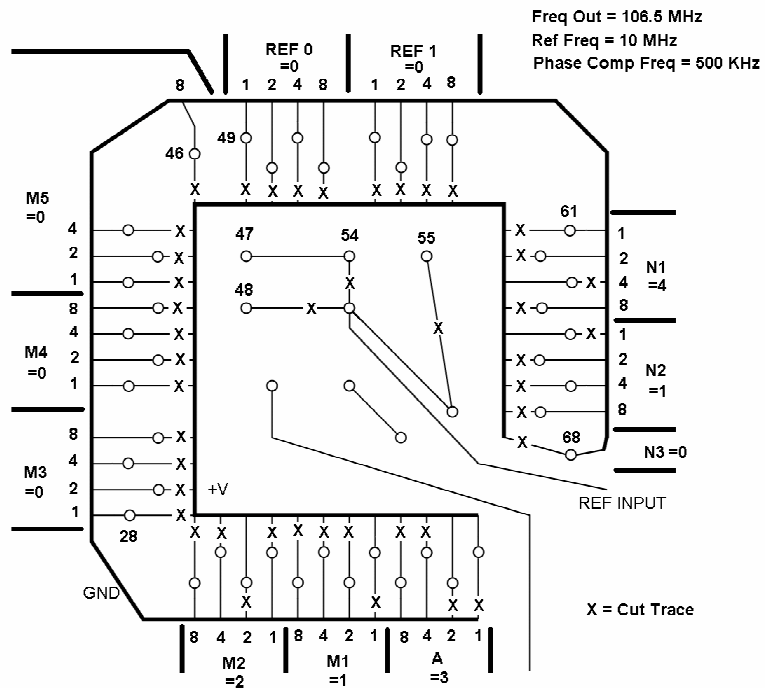

Figure 4 - Original Jumpers for 106.5 MHz Output and 10 MHz Ref

Notes

- The existing crystal is difficult to unsolder. The pins have sockets but they have been soldered. I believe the crystal can has been slightly soldered on the top side also. I was able to unsolder mine using a heat gun.
- When disassembling, be sure to take notes on which wire goes where. Some of the screws are difficult to remove because they have something like Loctite on them.
- When modifying cuts, be sure each pin is connected to one bus (+V or Gnd) and has a cut to the other. A value of 1 is assigned by having a jumper to +V and a cut to Gnd.

Loop Filter

The example that I received was for 106.25 MHz, 10 MHz Reference, and PD frequency of 625 KHz. Computations and jumpers for this were shown earlier. This example provided component values for loop filter components as follows:

Loop BW = 50 Hz

$R1 = R2 = 357$

$C4 = 0.47 \mu\text{F}$

$R5 = 24.3 \text{ K}$

$C1 = 2.2 \mu\text{F}$

$R8 = R12 = 619$

Unfortunately, I don't know where on the circuit board these components are located. I don't want to bother anyone at CTI about this as they have already gone out of their way providing this information. I assume if you examine the configuration of your existing unit and keep the PD frequency about the same (500 KHz for mine) and the output near 100 MHz, then the existing loop filter should work without changes.

If the loop filter turns out to be a problem for a combination that someone needs, maybe someone will want to take the time to reverse engineer the phase control circuit to find these loop filter components. I am hoping this won't be necessary to get good results for frequencies that are useful.

Planning Sheet

Output Frequency = MHz

Reference Frequency = MHz

Phase Detector (PD) Frequency = KHz

VCXO Divider No. (M) = OUT / PD =

$M = (M2 \cdot 100) + (M1 \cdot 10) + A$; therefore, $M2 =$, $M1 =$, $A =$

REF Divider No. (N) = REF / PD =

$N = ((256 \cdot N3) + (16 \cdot N2) + N1) (REF1+1) (REF0+1)$

therefore, $REF0 = 0$, $REF1 = 0$, $N3 = 0$, $N2 =$, $N1 =$

Jumper settings:

