

# Keysight 478A Thermistor Mount



Operating and  
Service Manual

# Notices

## Copyright Notice

© Keysight Technologies 2008 - 2020  
No part of this manual may be reproduced in any form or by any means (including electronic storage and retrieval or translation into a foreign language) without prior agreement and written consent from Keysight Technologies as governed by United States and international copyright laws.

## Manual Part Number

00478-90021

## Edition

Edition 3, January 23, 2020

## Printed in:

Printed in Malaysia

## Published by:

Keysight Technologies  
Bayan Lepas Free Industrial Zone,  
11900 Penang, Malaysia

## Technology Licenses

The hardware and/or software described in this document are furnished under a license and may be used or copied only in accordance with the terms of such license.

## Declaration of Conformity

Declarations of Conformity for this product and for other Keysight products may be downloaded from the Web. Go to <http://www.keysight.com/go/conformity>. You can then search by product number to find the latest Declaration of Conformity.

## U.S. Government Rights

The Software is “commercial computer software,” as defined by Federal Acquisition Regulation (“FAR”) 2.101. Pursuant to FAR 12.212 and 27.405-3 and Department of Defense FAR Supplement (“DFARS”) 227.7202, the U.S. government acquires commercial computer software under the same terms by which the software is customarily provided to the public. Accordingly, Keysight provides the Software to U.S. government customers under its standard commercial license, which is embodied in its End User License Agreement (EULA), a copy of which can be found at <http://www.keysight.com/find/sweula>. The license set forth in the EULA represents the exclusive authority by which the U.S. government may use, modify, distribute, or disclose the Software. The EULA and the license set forth therein, does not require or permit, among other things, that Keysight: (1) Furnish technical information related to commercial computer software or commercial computer software documentation that is not customarily provided to the public; or (2) Relinquish to, or otherwise provide, the government rights in excess of these rights customarily provided to the public to use, modify, reproduce, release, perform, display, or disclose commercial computer software or commercial computer software documentation. No additional government requirements beyond those set forth in the EULA shall apply, except to the extent that those terms, rights, or licenses are explicitly required from all providers of commercial computer software pursuant to the FAR and the DFARS and are set forth specifically in writing elsewhere in the EULA. Keysight shall be under no obligation to update, revise or otherwise modify the Software. With respect to any technical data as defined by FAR 2.101, pursuant to FAR 12.211 and 27.404.2 and DFARS 227.7102, the U.S. government acquires no greater than Limited Rights as defined in FAR 27.401 or DFAR 227.7103-5 (c), as applicable in any technical data.

## Warranty

THE MATERIAL CONTAINED IN THIS DOCUMENT IS PROVIDED “AS IS,” AND IS SUBJECT TO BEING CHANGED, WITHOUT NOTICE, IN FUTURE EDITIONS. FURTHER, TO THE MAXIMUM EXTENT PERMITTED BY APPLICABLE LAW, KEYSIGHT DISCLAIMS ALL WARRANTIES, EITHER EXPRESS OR IMPLIED, WITH REGARD TO THIS MANUAL AND ANY INFORMATION CONTAINED HEREIN, INCLUDING BUT NOT LIMITED TO THE IMPLIED WARRANTIES OF MERCHANTABILITY AND FITNESS FOR A PARTICULAR PURPOSE. KEYSIGHT SHALL NOT BE LIABLE FOR ERRORS OR FOR INCIDENTAL OR CONSEQUENTIAL DAMAGES IN CONNECTION WITH THE FURNISHING, USE, OR PERFORMANCE OF THIS DOCUMENT OR OF ANY INFORMATION CONTAINED HEREIN. SHOULD KEYSIGHT AND THE USER HAVE A SEPARATE WRITTEN AGREEMENT WITH WARRANTY TERMS COVERING THE MATERIAL IN THIS DOCUMENT THAT CONFLICT WITH THESE TERMS, THE WARRANTY TERMS IN THE SEPARATE AGREEMENT SHALL CONTROL.

## Safety Information

### CAUTION

A CAUTION notice denotes a hazard. It calls attention to an operating procedure, practice, or the like that, if not correctly performed or adhered to, could result in damage to the product or loss of important data. Do not proceed beyond a CAUTION notice until the indicated conditions are fully understood and met.

### WARNING

A WARNING notice denotes a hazard. It calls attention to an operating procedure, practice, or the like that, if not correctly performed or adhered to, could result in personal injury or death. Do not proceed beyond a WARNING notice until the indicated conditions are fully understood and met.

## Certification

Keysight Technologies certifies that this product met its published specifications at the time of shipment. Keysight further certifies that its calibration measurements are traceable to the United States National Institute of Standard and Technology (formerly National Bureau of Standards), to the extent allowed by that organization's calibration facility, and to the calibration facilities of other International Standards Organization members.

## Warranty Information

This Keysight Technologies instrument product is warranted against defects in material and workmanship for a period of one year from date of shipment. During the warranty period, Keysight Technologies will at its option, either repair or replace products which prove to be defective. For warranty service or repair, this product must be returned to a service facility designated by Keysight Technologies. Buyer shall prepay shipping charges to Keysight Technologies and Keysight Technologies shall pay shipping charges, duties, and taxes for products returned to Keysight Technologies from another country. Keysight Technologies warrants that its software and firmware designated by Keysight Technologies for use with an instrument will execute its programming instructions when properly installed on that instrument. Keysight Technologies does not warrant that the operation of the instrument, or firmware will be uninterrupted or error free.

## Limitation of Warranty

The foregoing warranty shall not apply to defects resulting from improper or inadequate maintenance by Buyer, Buyer-supplied software or interfacing, unauthorized modification or misuse, operation outside of the environmental specifications for the product, or improper site preparation or maintenance. NO OTHER WARRANTY IS EXPRESSED OR IMPLIED. KEYSIGHT TECHNOLOGIES SPECIFICALLY DISCLAIMS THE IMPLIED WARRANTIES OF MERCHANTABILITY AND FITNESS FOR A PARTICULAR PURPOSE.

## Exclusive Remedies

THE REMEDIES PROVIDED HEREIN ARE BUYER'S SOLE AND EXCLUSIVE REMEDIES. KEYSIGHT TECHNOLOGIES SHALL NOT BE LIABLE FOR ANY DIRECT, INDIRECT, SPECIAL, INCIDENTAL, OR CONSEQUENTIAL DAMAGES, WHETHER BASED ON CONTRACT, TORT, OR ANY OTHER LEGAL THEORY.

## Safety Considerations

Read the information below before using this instrument.

The following general safety precautions must be observed during all phases of operation, service, and repair of this instrument. Failure to comply with these precautions or with specific warnings elsewhere in this manual violates safety standards for design, manufacture, and intended use of the instrument. Keysight Technologies assumes no liability for the customer's failure to comply with these requirements.

### CAUTION

- This product is designed for use in Installation Category II and Pollution Degree 2.
  - This instrument has been designed and tested in accordance with IEC Publication 348, Safety Requirements for Electronic Measuring Apparatus, and has been supplied in a safe condition. The instruction documentation contains information and warnings which must be followed by the user to ensure safe operation and to maintain the instrument in a safe condition.
  - "CSA" The CSA mark is a registered trademark of the Canadian Standards Association.
  - Notice for Germany: Noise Declaration LpA < 70 dB am Arbeitsplatz (operator position) normaler Betrieb (normal position) nach DIN 45635 T. 19 (per ISO 7779).
-

## Waste Electrical and Electronic Equipment (WEEE) Directive

This instrument complies with the WEEE Directive marking requirement. This affixed product label indicates that you must not discard this electrical or electronic product in domestic household waste.

### Product category:

With reference to the equipment types in the WEEE directive Annex 1, this instrument is classified as a “Monitoring and Control Instrument” product.

The affixed product label is as shown below.



Do not dispose in domestic household waste.

To return this unwanted instrument, contact your nearest Keysight Service Center, or visit <http://about.keysight.com/en/companyinfo/environment/takeback.shtml> for more information.

## Sales and Technical Support

To contact Keysight for sales and technical support, refer to the support links on the following Keysight websites:

- [www.keysight.com/find/478a](http://www.keysight.com/find/478a)  
(product-specific information and support, software and documentation updates)
- [www.keysight.com/find/assist](http://www.keysight.com/find/assist)  
(worldwide contact information for repair and service)

THIS PAGE HAS BEEN INTENTIONALLY LEFT BLANK.

# Table of Contents

Certification	3
Warranty Information	3
Limitation of Warranty	3
Exclusive Remedies	4
Safety Considerations	4
Waste Electrical and Electronic Equipment (WEEE) Directive	5
Product category:	5
Sales and Technical Support	5
List of Figures	9
List of Tables	11
<b>1 General Information</b>	
Introduction	15
Instruments Covered by Manual	15
Incoming Inspection	15
<b>2 Operation</b>	
Biasing Thermistors	18
Maximum Input	18
Average Power	18
Pulse Energy and Peak Power for 478A/432 Combination	19
Pulse Energy and Peak Power for 478A/431 Combination	20
Zero Set	22
RF Power Turned Off for Zero-Set	22
Thermistor Mount Disconnected for Zero Set	23
Thermoelectric Effect	26
Thermoelectric Effect Error Correction for 478A / 431 Combination	27
Thermoelectric Error for 478A / 432 Combination	27
Circuit Description	28
431 Power Meter Detection	29

432 Power Detection	29
<b>3 Specifications and Characteristics</b>	
<b>4 Maintenance</b>	
Mechanical Shock	34
Check on Thermistor Match	34
Repair	36
Thermistor Assembly Replacement Procedure	39
Removal Procedure	41
Installation Procedure	42
Recalibration	43
<b>A Appendix A</b>	
Introduction	46
How to Use This Appendix	46
Manual Changes	47
Change A	47
Change B	50



## List of Figures

Figure 1-1	Keysight Model 478A Thermistor Mount	14
Figure 2-1	Maximum Power Meter Reading vs PRF for Pulses Shorter than 250 $\mu$ s	19
Figure 2-2	Maximum Power Meter Reading vs Duty Cycle for Pulses Longer than 250 ms	20
Figure 2-3	Maximum Power Meter Reading vs Square and Sine-Wave Frequency	21
Figure 2-4	Source Impedance Shunting One RF Thermistor Mount	23
Figure 2-5	Schematic Diagram of a Model 478A Thermistor Mount when Connected to a 431 Power Meter	25
Figure 4-1	Schematic Diagram of a Model 478A Thermistor Mount when Connected to a 432 Power Meter	34
Figure 4-2	Check on Model 478A Thermistor Resistance Match	35
Figure 4-3	Thermistor Compensation	37
Figure 4-4	Model 478A Thermistor Mount Assembly	41
Figure 4-5	Keysight Model 478A Printed Circuit Assy Wiring	42
Figure A-1	Schematic Diagram of a Model 478A Thermistor Mount when Connected to a 431 Power Meter. (P/O Change A)	47
Figure A-2	Schematic Diagram of a Model 478A Thermistor Mount when Connected to a 432 Power Meter. (P/O Change A)	48
Figure A-3	Check on Model 478A Thermistor Resistance Match (P/O Change A)	49
Figure A-4	Source Impedance Shunting One RF Thermistor Mount (P/O Change B)	50
Figure A-5	Schematic Diagram of a Model 478A Thermistor Mount when Connected to a 431 Power Meter. (P/O Change B)	51
Figure A-6	Schematic Diagram of a Model 478A Thermistor Mount when Connected to a 432 Power Meter. (P/O Change B)	52
Figure A-7	Thermistor Compensation (P/O Change B)	53

Figure A-8	Model 478A Thermistor Mount Assembly (P/O Change B) .....	53
Figure A-9	Keysight Model 478A Printed Circuit Assembly Wiring (P/O Change B) .....	54

## List of Tables

Table 2-1	Methods of Switching Off RF Output of Various Keysight Signal Generators . . . . .	22
Table 4-1	Replaceable Parts . . . . .	39
Table A-1	Manual Changes by Serial Number . . . . .	46

THIS PAGE HAS BEEN INTENTIONALLY LEFT BLANK.

# 1 General Information

Introduction 15



**Figure 1-1** Keysight Model 478A Thermistor Mount

## Introduction

The Keysight model 478A coaxial thermistor mount is designed for use with Keysight model 431 and 432 power meters to measure microwave power from 1  $\mu\text{w}$  to 10 mw. Design of the mount minimizes adverse effects from environmental temperature changes during measurement. For increased measurement accuracy, Effective Efficiency and Calibration Factor are measured for each mount, and at selected frequencies across the operating range; the results are marked on the label of the instrument (see “Mount Calibration Data” in [Chapter 3, "Specifications and Characteristics"](#)). The model 478A can be used over the 10-HMZ to 10-GHz frequency range. Throughout the range, the mount terminates the coaxial input in a 50  $\Omega$  impedance, and has a SWR of not more than 1.75 without external tuning.

Each mount contains two series pairs of thermistors, which are matched to cancel the effects of drift with ambient temperature change. Thermal stability is accomplished by mounting the leads of all four thermistors on a common thermal conductor to ensure a common thermal environment. This conductor is thermally insulated from the main body of the mount so the thermal noise or shocks applied externally to the mount, such as those handling the mount manually, cannot significantly penetrate to disturb the thermistor. This thermal immunity enables the thermistors to be used in the measurement of microwave power down to the microwatt region.

## Instruments Covered by Manual

Instruments with serial numbers 79401 and below are documented directly by this manual. Some instruments with serial numbers lower than 79401 may be documented in [Appendix A](#); other instruments with serial numbers higher than 79401 may be documented in a MANUAL CHANGES supplement.

## Incoming Inspection

Inspect the model 478A upon receipt for mechanical damage. Also check it electrically; if the mount was subjected to severe mechanical shock during shipment, the match between thermistors may be affected. To check the thermistor match, proceed as described in [“Check on Thermistor Match”](#) on page 34.

If any damage is found, inform the carrier and your nearest Keysight Sales and Service Office immediately.

THIS PAGE HAS BEEN INTENTIONALLY LEFT BLANK.



# 2 Operation

Biasing Thermistors 18

## Biassing Thermistors

### CAUTION

**Mechanical Shock:** Do not drop or subject to severe mechanical shock. Shock may destroy the match between thermistors and increase susceptibility to drift.

---

### CAUTION

Before connecting the model 487A to the 431 or 432 power meters, set the MOUNT RES switch to 200 W position. **CONNECTING A 200 W MOUNT TO A POWER METER SET FOR A 100 W MOUNT CAN RESULT IN THERMISTOR DAMAGE.**

---

## Maximum Input

The model 478A/431 and 478A/432 combinations respond to the average RF power applied. The maximum signal applied to the thermistor mount should not exceed the limitations for

- average power
- pulse energy
- peak pulse power

Excessive input can permanently damage the model 478A by altering the match between RF and compensation thermistors (resulting in excessive drift or zero shift) or cause error in indicated power.

## Average Power

The 478A/431 and 478A/432 combinations can measure average power up to 10 mW. To measure power in excess of 10 mW, insert a calibrated directional coupler such as one of the Keysight Technologies model 770 series or 790 series between the mount and the source. **UNDER NO CIRCUMSTANCES APPLY MORE THAN 30 mW AVERAGE POWER TO THE MOUNT.**

## Pulse Energy and Peak Power for 478A/432 Combination

For pulses shorter than 250  $\mu\text{s}$ , energy per pulse must not exceed 10 W- $\mu\text{s}$  and peak power should never exceed 200 watts. (For example, a 40 mW, 250  $\mu\text{s}$  pulse contains 10 W- $\mu\text{s}$  of energy.) Pulses longer than 250  $\mu\text{s}$  are allowed to contain more energy but peak power must not exceed 200 W. [Figure 2-1](#) and [Figure 2-2](#) interpret these limits in graphical form. (For lack of space, the mount nameplate lists only a 5 W- $\mu\text{s}$  limit, a rating which applies to the 487A/431 combination.)

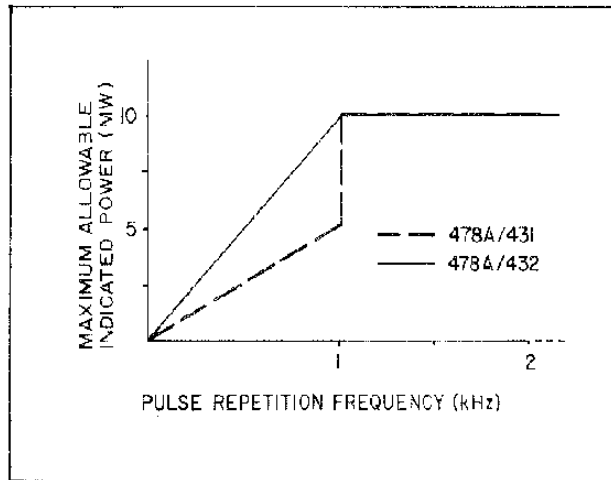

**Figure 2-1** Maximum Power Meter Reading vs PRF for Pulses Shorter than 250  $\mu\text{s}$

## Pulse Energy and Peak Power for 478A/431 Combination

The limitations of this combination are basically the same as the 487A/432 with the exception that at pulse repetition rates less than 1 kHz, energy per pulse must not exceed 5 W- $\mu$ s and peak power must not exceed 10 mW. These limits are also interpreted in [Figure 2-1](#) and [Figure 2-2](#).

Square-wave modulation is a special case of pulse modulation, and maximum power-meter reading versus square-wave frequency is illustrated in [Figure 2-3](#). This figure also holds for sine-wave modulation.

In the discussions above, the primary consideration is maximum power or energy. However, for modulation frequencies less than 100 Hz, the low repetition frequency itself causes errors in indicated power. These errors may be as large as two percent regardless of range or reading.

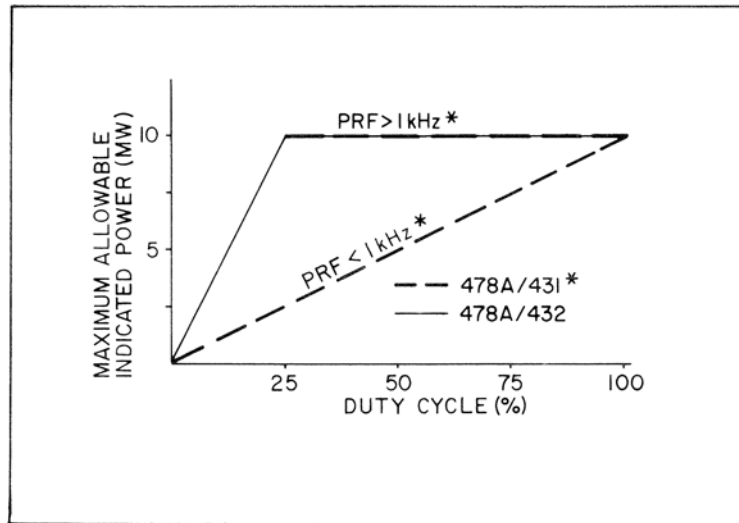

**Figure 2-2** Maximum Power Meter Reading vs Duty Cycle for Pulses Longer than 250  $\mu$ s

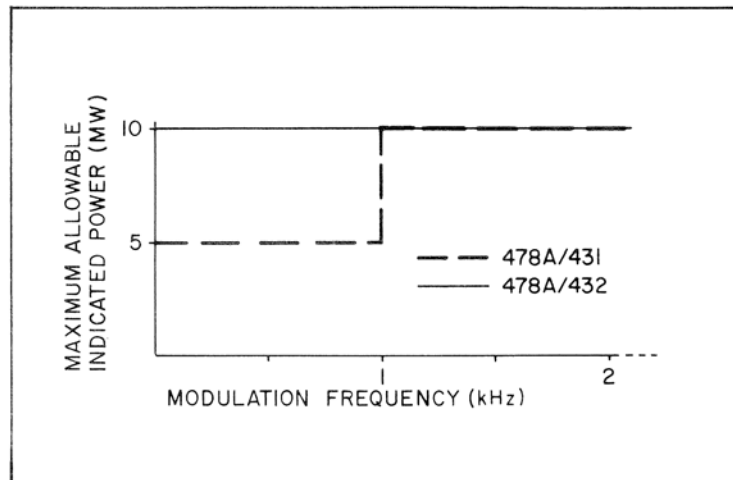

**Figure 2-3** Maximum Power Meter Reading vs Square and Sine-Wave Frequency

When RF is switched by pulse-gating (coaxial solid state switches), consideration must be given to the RF energy contained in the switching pulse itself. This energy must be added to actual RF pulse power when estimating the RF power dissipated in the thermistor mount. PIN diode modulators of Keysight model 8741A/8716A modulators and 8614A/8616A signal generators, however, are not subject to this consideration because output filtering prevents transmission of modulating signals.

### CAUTION

Thermistors are inherently temperature-sensitive devices. A cold thermistor mount connected to a warm piece of equipment, or vice versa, produces rapid shift. FOR MINIMUM DRIFT ON SENSITIVE RANGES, MAKE SURE THAT THE MOUNT AND THE EQUIPMENT CONNECTED TO IT ARE AT NEARLY THE SAME TEMPERATURE BEFORE MAKING A MEASUREMENT.

## Zero Set

It is necessary to electrically zero-set the model 431/432 power meter before making a power measurement. To preserve the same zero reference throughout the measurement, maintain the same thermal environment when RF power is applied. Two recommended set-ups for 431 zero-setup are presented in “[RF Power Turned Off for Zero-Set](#)” on page 22 and “[Thermistor Mount Disconnected for Zero Set](#)” on page 23. The recommended set-up for zero-set in the 432 is shown in “[478A/432](#)” on page 25.

## RF Power Turned Off for Zero-Set

There is minimum zero drift when the zero is set with the RF system connected to the thermistor mount and the RF power switch off or greatly attenuated by the generator attenuator. The methods used to switch off RF output in Keysight signal generators are listed in [Table 2-1](#). After allowing time for the mount to stabilize thoroughly, follow zero-set procedures in the 431 or 432 power meter manual and then turn on the RF source.

**Table 2-1** Methods of Switching Off RF Output of Various Keysight Signal Generators

Keysight Generator	Frequency Range	Procedure to Switch Off RF Output
Model 606	50 kHz to 65 MHz	Increase the generator output attenuation 30 or more dB
Model 8614A / 8616A	800 to 2400 MHz / 1800 to 4500 MHz	Release RF push button
Model 614 / 616	800 to 2100 MHz / 1800 to 4200 MHz	Set modulation selector to OFF
Model 618 / 620	3.8 to 7.6 GHz / 7 to 11 GHz	Set modulation selector to OFF
Model 608	10 to 480 MHz / 10 to 420 MHz	Set MOD SELECTOR to PULSE, but do not apply modulation signal to modulation input terminal
Model 682 / 687	1 to 2 GHz / 12.4 to 18.0 GHz	Set MOD SELECTOR to PULSE, but do not apply modulation signal to modulation input terminal
Model 612	450 to 1230 MHz	Set MOD SELECTOR to PULSE 2, but do not apply modulation signal to modulation input terminal
Model 690, 8690 Series	1 to 20 GHz	Set LINE to STANDBY

## Thermistor Mount Disconnected for Zero Set

### 478A/431

When it is inconvenient to turn off the RF power in the RF system, connect the model 478A mount to the RF system and set RANGE on the model 431 power meter for an appropriate midscale reading. When the reading no longer drifts, disconnect the mount from the source, terminate the mount, if necessary, as described in “[Thermistor Mount Disconnected for Zero Set](#)” on page 23, and then zero-set the power meter. Immediately reconnect the mount to the RF source for the power measurement.

#### NOTE

In the proximity of a high RF field, shield the disconnected thermistor mount from possible stray RF pick-up during the zero-set.

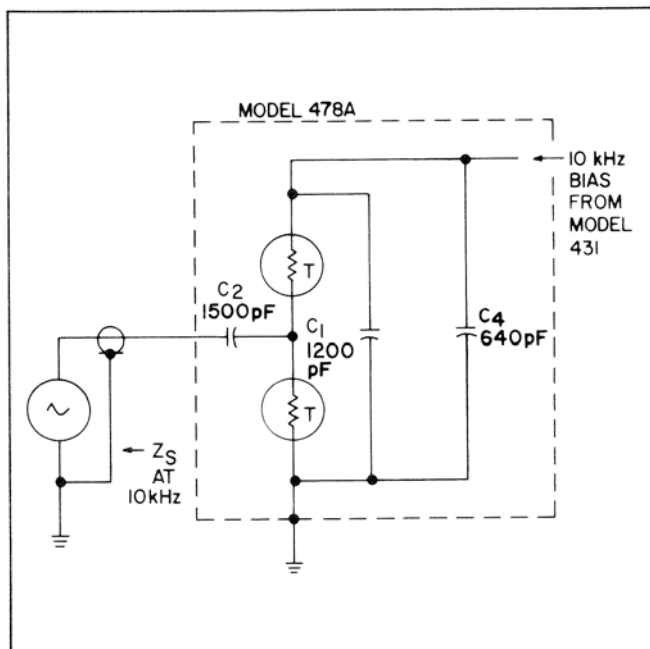

**Figure 2-4** Source Impedance Shunting One RF Thermistor Mount

With the model 478A mount connected to the RF system, the source impedance shunts one of the RF thermistors (see [Figure 2-4](#)); when the model 478A mount is disconnected, the source impedance is removed. Unless source impedance is high, this variation in impedance affects the RF bridge 10-kHz feedback loop in the power meter, and the zero-level setting obtained with the source disconnected is no longer zero for the measurement. This error can be eliminated by terminating the mount in an impedance which approximately matches the generator impedance at 10 kHz; the termination should be connected while the mount is disconnected (see [“Thermistor Mount Disconnected for Zero Set”](#) on page 23) from the source. For example, if the impedance presented by the RF system to 10 kHz is low (1 k $\Omega$  or less) terminate the thermistor mount in a 50  $\Omega$  resistor or a short. On the other hand, if the impedance of the RF system at 10 kHz is high (100 k $\Omega$  or more) leave the thermistor mount unterminated during zero-set.

Note that some 10-kHz bias signal is coupled into the RF transmission system by C2 ([Figure 2-5](#)). If the Rf source output impedance at 10 kHz is 15 k $\Omega$  or greater, 10-kHz bias voltage is typically 1.3 V RMS and could equal 1.5 V RMS. For an RF source output impedance of 50  $\Omega$  at 10 kHz, bias signal voltage is typically 5 mV RMS.

The presence of this 10-kHz bias signal may affect solid state RF sources and RF voltmeter measurements. To minimize or eliminate these effects, use an additional blocking capacitor at the model 478A or a high pass filter at the RF source output.



### 478A/432

When it is inconvenient to turn the RF power off while using the 478A/432 combination simply remove the mount from the source, and using the COARSE and FINE ZERO, zero the 432.

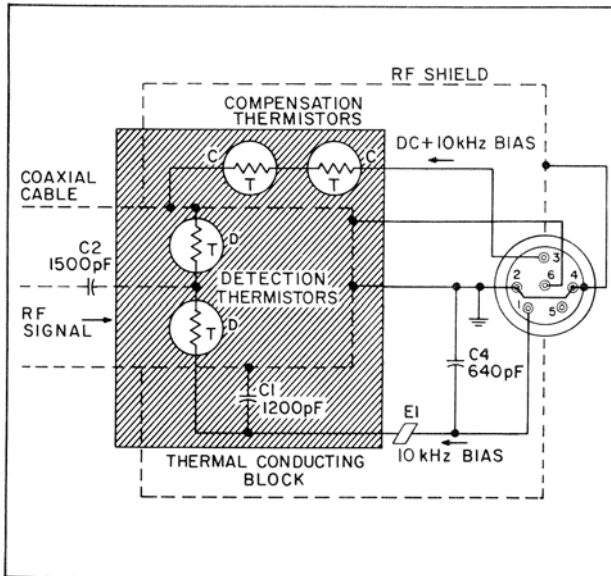

**Figure 2-5** Schematic Diagram of a Model 478A Thermistor Mount when Connected to a 431 Power Meter

## Thermoelectric Effect

Mount calibration uncertainties given in [Chapter 3, "Specifications and Characteristics"](#) include inaccuracies caused by thermoelectric effect error. Calibration Factor uncertainty of  $\pm 1.5\%$  and Effective Efficiency uncertainty of  $\pm 2.5\%$  can be maintained on the three lowest power ranges of the model 431 series power meters by correcting for the measurement error introduced by thermoelectric effect. An error correction procedure is given in ["Thermoelectric Effect Error Correction for 478A / 431 Combination"](#) on page 27.

A mild thermocouple exists at each point of contact where the connecting wires to join the thermistor elements. Each thermocouple creates a DC voltage. Thus, two thermocouple voltages of opposite relative polarity are formed, one at each junction to each thermistor element.

Ideally, each thermocouple voltage would be equal in magnitude so that they cancel with no resultant effect on the accuracy of power measurement. In practice however, each point of contact does not have identical thermocouple characteristics, and in addition, the temperatures at each junction may not be the same. These differences cause an incomplete cancellation of the thermoelectric voltages, resulting in a voltage that causes a thermoelectric effect error. The magnitude of the error is important when making DC substitution measurements on the 0.1 mW, 0.03 mW and 0.01 mW ranges with one of the model 431 series power meters. On other ranges, the effect is negligible. Maximum error introduced by thermoelectric effect is about 0.3  $\mu\text{W}$  and is typically 0.1  $\mu\text{W}$  on the 0.01 mW range.

## Thermoelectric Effect Error Correction for 478A / 431 Combination

Use the following technique to correct for thermoelectric effect error.

- 1** Measure power
- 2** Connect an Keysight model 8402 power meter calibration to the power meter DC CALIBRATION AND SUBSTITUTION connector.
- 3** Zero and null power meter.
- 4** By DC substitution (refer to procedure in 431 Manual), duplicate power measurement made in step 1. Calculate and record substituted power as  $P_1$ .
- 5** Reverse connection polarity between the calibrator and power meter.
- 6** Re-zero and re-null power meter, if necessary.
- 7** By DC substitution, duplicate lower measurement made in step 1. Calculate and record substituted power as  $P_2$ .
- 8** Calculate arithmetic mean of the two substitution powers  $P_1$  and  $P_2$ . This mean power includes a correction for thermoelectric effect error.

$$\text{Power} = \frac{P_1 + P_2}{2}$$

## Thermoelectric Error for 478A / 432 Combination

The thermoelectric errors present in the 431 are minimized in the 432 since the thermoelectric voltage is negligible compared with the DC voltage used to bias the thermistor bridges.

## Circuit Description

Two matched series thermistors are mounted on a common thermal conducting block, represented by the shaded rectangle in [Figure 2-5](#). One pair, marked “D” for detection, is mounted between the end of a coaxial cable and cylindrical cavity. These thermistors are exposed to incoming RF power which heats them, lowering their resistance. The other pair, marked “C” for compensation and situated immediately outside the cavity, is completely shielded from RF. With the 478A attached to 431 power meter, the detection thermistors are part of the metering circuit.

With the 478A attached to the 432 power meter, the detection thermistors are part of the RF bridge and the compensation thermistors are part of the compensation bridge. Since the two pairs of thermistors show the same thermal environment, any change in temperature which affects the RF bridge simultaneously affects the mastering bridge; this allows the power meter circuit to compensate for changes in temperature and thus minimize drift.

During 431/478A operation, sufficient amounts of DC and 10 kHz bias currents are supplied from the 431 power meter to heat the thermistors until their resistances are reduced to approximately 200  $\Omega$  per series pair. Capacitor C1 offers high impedance to 10 kHz, but is practically a short of RF. This causes “D” to appear series connected to 10 kHz, but parallel connected to RF. In this manner, “D” appears to the audio bridge of the 431 power meter as a 200  $\Omega$  resistance, but terminates the coaxial cable in 50  $\Omega$ . Capacitor C2 blocks any DC and audio power that may be present in the incoming signal, and passes only RF power.

During 432 operation (see [Figure 4-1](#)) sufficient amounts of DC current are supplied from 432 power meter to heat the thermistors until their resistances are reduced to approximately 200  $\Omega$  per series pair. Capacitor C1 is practically a short to RF. This causes “D” to appear series connected to the DC bridge, parallel connected to RF. In this manner, “D” appears to the DC bridge in the 432 power meter as a 200  $\Omega$  resistance that terminates the coaxial cable into 50  $\Omega$ . Capacitor C2 blocks any DC and audio power that may be present in the incoming signal and passes only RF power.

### 431 Power Meter Detection

Under normal operation, the total power supplied to heat thermistor pair “D” (see [Figure 2-5](#)) consists of:

- RF signal
- 10 kHz bias
- Heat from the same environment

As “D” and “C” are matched thermally, the total amounts of heat applied to reduce their series resistance equally must be equal.

### 432 Power Detection

Under normal operation, the total power applied to heat thermistor pair “D” (see [Figure 4-1](#)) consists of:

- RF signal
- Heat from the environment

The total power supplied to heat thermistor “C” consists of:

- DC bias
- Heat from the same environment

As “D” and “C” are matched thermally, the total amounts of heat applied to reduce their series resistance equally must be equal.

THIS PAGE HAS BEEN INTENTIONALLY LEFT BLANK.

# 3 Specifications and Characteristics

For the specifications and characteristics of the 478A Thermistor Mount, refer to the datasheet at <http://literature.cdn.keysight.com/litweb/pdf/5990-5740EN.pdf>

THIS PAGE HAS BEEN INTENTIONALLY LEFT BLANK.



# 4 Maintenance

Mechanical Shock 34

## Mechanical Shock

The model 478A is a precision instrument. Avoid dropping or other mechanical shocks. Such shocks can destroy the match between the thermistors.

### Check on Thermistor Match

Match between the thermistors may be checked by comparing the thermistor resistances under simulated operating conditions. Equipment required is indicated in [Figure 4-1](#). Make connection to the connector at the rear of the thermistor mount; pins are shown in [Figure 4-1](#). Note that the small battery in series with the Keysight model 3440 digital voltmeter is connected in opposition to the power supply. The value of this bucking voltage should be such that voltmeter resolution down to 0.001 volt is obtained. Take readings with switch S connected to pin 1 and then to pin 3. Thermistor match is satisfactory if the two readings do not differ by more than 0.030 volt. Non-operating mounts with readings as high as 0.150 volt can probably be repaired as outlined in the succeeding paragraphs.

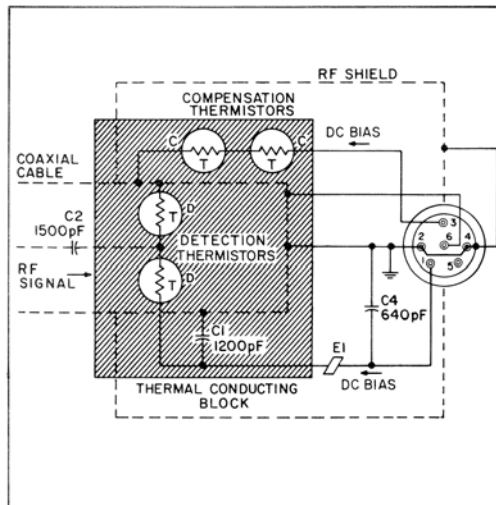

**Figure 4-1** Schematic Diagram of a Model 478A Thermistor Mount when Connected to a 432 Power Meter

**WARNING**

Under no conditions should the mount be required to carry a current higher than 14 mA.

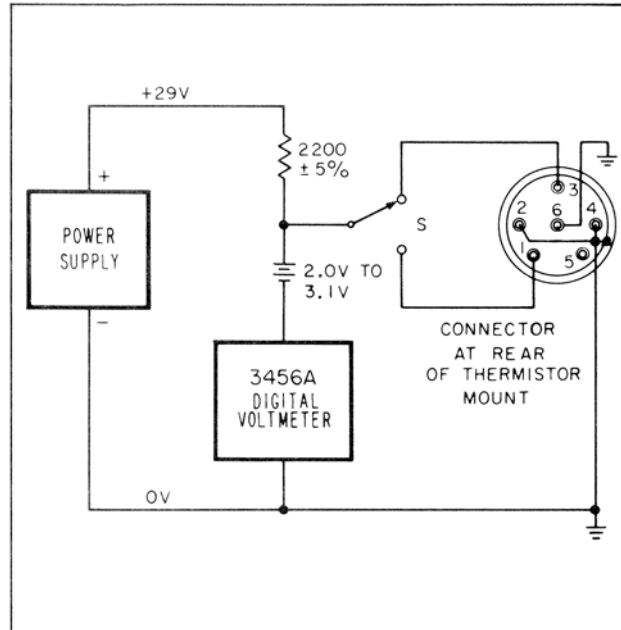

Figure 4-2 Check on Model 478A Thermistor Resistance Match

## Repair

Exceeding the cw or pulse power limit of the model 478A thermistor mount may result in damage such that the mount will no longer zero on the model 431 or 432 power meter.

Before adjusting the mount in any way, make sure that the mount is the cause of the problem. An open or short indication, using the checks in “[Check on Thermistor Match](#)” on page 34, or “[Repair](#)” on page 36, means that the mount is not repairable by the procedures outlined in the following paragraphs. However, the mount may be nonoperative but still repairable. Test for this by using the procedures in [Chapter 4](#), “Check on Thermistor Match,” starting on page 34, or by connecting the mount to a model 431 or 432 power meter and a cable which is known to be good. A faulty cable will not have continuity through the respective connector pins or may have poor contact in the mount connector. Poor contact will show as an intermittancy or a great deal of noise (visible on 431 or 432 meter) when the cable is gently flexed near the connector end.

### NOTE

The following procedures are set down for the 431/478A combination. The same procedures can be used for the 432 except for the ZERO/VERNIER control. Those controls on the 431 are replaced by the COARSE ZERO and FINE ZERO control on the 432.

The major difference between the 478A/431 and 478A/432 combination is that the 478A/432 combination does not use 10 kHz as a biasing factor in the thermistor. All biasing factors in the 432 are from DC sources therefore, lowering the thermoelectric effect.

To troubleshoot a damaged mount, proceed as follows:

- 1 Connect Mount to model 431.
- 2 Set:
 

MOUNT RES:	200 $\Omega$
RANGE:	10 mW
POWER:	ON
- 3 Rotate ZERO from one limit to the other.

If the meter remains pegged upscale, the thermistor elements have been damaged. However, it may be possible to recompensate the thermistors (refer to “Repair” on page 36) and return the mount to operation: otherwise they must be replaced. In either case, the Effective Efficiency and Calibration Factor data on the nameplate are no longer valid (see “Recalibration” on page 43).

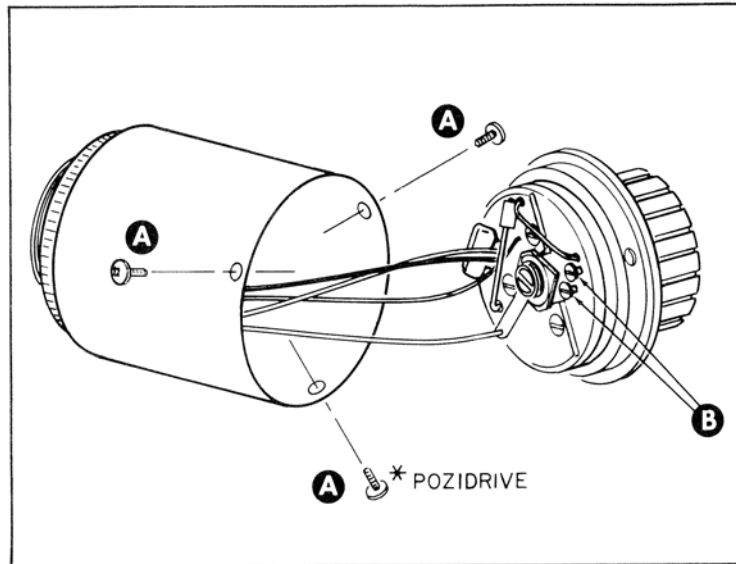

**Figure 4-3** Thermistor Compensation

If meter remains pegged downscale, measure resistance between pins 1 and 2, and pins 3 and 4. The resistance should measure between 1000 and 5000  $\Omega$ . An open or shorted reading indicates the need for replacement of the thermistors.

If the resistance reading is satisfactory, it may be possible to recompensate the mount and return it to service. The drift with temperature changes will be higher because of the damage to the thermistors, but it will be possible to zero the meter and to make measurements. The Effective Efficiency and Calibration Factor indicated on the label will no longer be valid (see “Recalibration” on page 43). There are two adjusting screws inside the instrument which permit recompensation within limits. Most instruments with serial lower than 7663 do not have the adjusting screws at the time of manufacture, but are modified if the instrument was sent in for repair after March 1964.

Refer to [Figure 4-3](#) and proceed as follows:

- 1 Remove the three screws (A).
- 2 Slide instrument out of its cover.
- 3 Plug cover into model 431.
- 4 Set:

MOUNT RES:	200 $\Omega$
MOWER:	ON

If meter is pegged downscale:

- 1 Set RANGE to 10 mW.
- 2 Set ZERO and VERNIER to mid-range.
- 3 Turn screws (B) clockwise, 1/8 turn alternatively.

**CAUTION**

If there is a sudden jump in meter indication when advancing either screw, back off 1/8 turn, and do not advance that screw further. Check resistance as in [“Repair”](#) on page 36. If either screws bottoms, do not apply force. Thermistor replacement (see [“Thermistor Assembly Replacement Procedure”](#) on page 39) is indicated.

---

- 4 When meter pointer rises, trim to zero with each adjusting screw.
- 5 Replace cover and three screws (A). The instrument is now operative.

**NOTE**

Make sure the three screws in the body of the thermistor mount are tight when the mount is put together; this insures quiet operation.

---

If the meter is pegged upscale:

- 1 Set ZERO and VERNIER to mid-range.
- 2 Set RANGE to highest position which will not peg the meter.
- 3 Turn one of the screws (B) counterclockwise to obtain a meter reading half that observed in step 2.
- 4 Turn the other screw (B) counterclockwise to zero the meter. If it is impossible to zero the meter, replace the thermistors (see “[Thermistor Assembly Replacement Procedure](#)” on page 39).
- 5 Replace cover and three screws (A). The instrument is now operative.

## Thermistor Assembly Replacement Procedure

### NOTE

After replacement of the thermistor assembly, the Effective Efficiency and Calibration Factor indicated on the label of the mount are no longer valid (see “[Recalibration](#)” on page 43).

The procedure consists of removing the damaged thermistor assembly, the printed circuit assembly and replacing them with pretested assemblies included in Thermistor Assembly Replacement Kit, Keysight Stock No. 00478-60002 (see [Table 4-1](#)).

**Table 4-1** Replaceable Parts

Keysight Part Number	Qty	Description
0520-0136	3	Screw, 2-56 x 5/8 , RDHD
0520-0173	3	Screw, 2-56 x 3/16, PNHD
1251-0153	1	Receptacle Connector
1251-1281	1	Nut, Knurled
1460-1547	1	Spring, Compressor
2190-0014	3	Internal Lock Washer No.2
2190-0036	1	Washer Lock, 818 ID
08491-2009	1	Sliding Contact

**Table 4-1** Replaceable Parts (continued)

Keysight Part Number	Qty	Description
00478-60002	1	Thermistor Assembly (includes 478A-65A and components)
00478-60003	1	Connector Assembly
00478-60001	1	Terminal Shield
478A-54A	3	Insulator Bushing

The replacement assemblies are pretested at the factory. However, since the operation of the thermistor mount depends on proper installation of the assembly, it may be desirable to check the SWR and efficiency following replacement. The efficiency may be checked by comparing against a known mount. The SWR is checked at 9 GHz and 10 GHz. SWR should be approximately equal at 9 and 10 GHz, and should be 1.5 or less.

**NOTE**

In the field, replaceable thermistor assembly connection of the RF thermistors to the Type N center conductor, SWR will be about 2.0 at 10 GHz. The bellows may be lengthened slightly with a pair of tweezers.

The following special tools may be required for the completion of this procedure:

- One small screwdriver, 0.070 tip, suitable for removing a 00-90 x 1/8 screw.
- One pair of tweezers.



## Removal Procedure

- 1 Remove three 2-56 x 3/16 screws holding terminal shield (Figure 4-5). Move terminal shield aside.

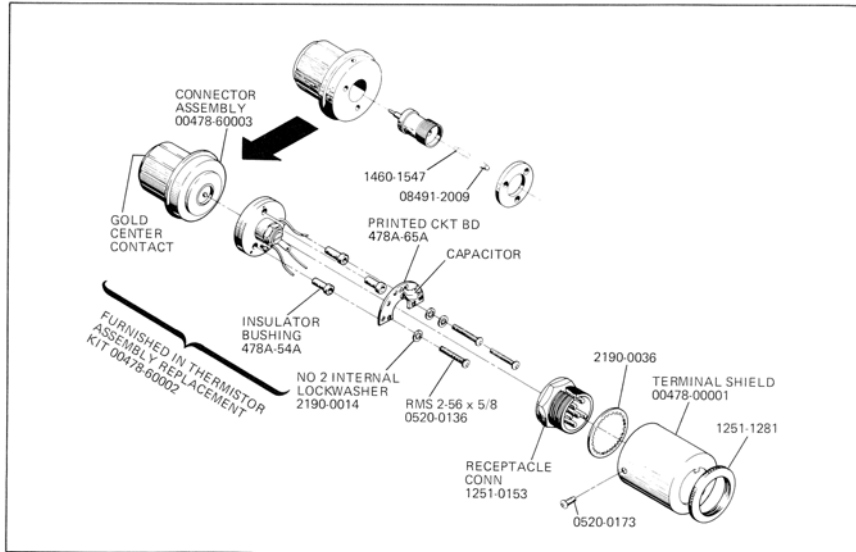

**Figure 4-4** Model 478A Thermistor Mount Assembly

### CAUTION

Do not break wires connecting printed circuit assembly to receptacle connector.

- 2 Loosen locknut and remove 5/16-32 setscrew from thermistor assembly.
- 3 Disconnect the three wires between the printed circuit assembly and the receptacle connector from the printed circuit assembly.
- 4 In early thermistor assemblies there is a 00-90 x 1/8 screw used to connect the RF Thermistors to the Type N center conductor. Remove this screw, if present, using small screwdriver and tweezers.
- 5 Remove the three 2-56 x 5/8 inch screws holding printed circuit and thermistor assemblies to the RF connector assembly.

- 6 Remove printed circuit and thermistor assemblies.
- 7 Remove the three insulator bushings from thermistor assembly. This completes the removal of the damaged assembly.

## Installation Procedure

- 1 Referring to [Figure 4-5](#), connect the three wires from receptacle connector to printed circuit assembly.

### NOTE

For strain relief, the wires should go through the holes indicated and connect from the bottom of the printed circuit assembly.

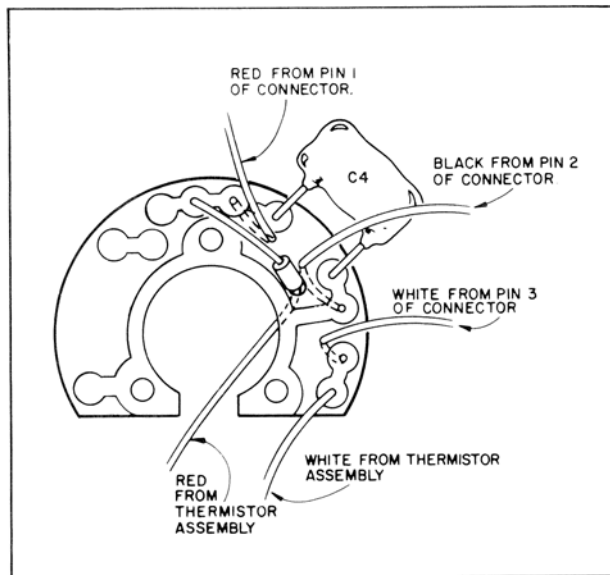

**Figure 4-5** Keysight Model 478A Printed Circuit Assy Wiring

- 2 Install the three insulator bushings in the thermistor assembly.
- 3 Pass the red wire from the thermistor assembly through the hole indicated in [Figure 4-5](#). Do not connect to printed circuit assembly at this time.

- 4 Mount thermistor and printed circuit assemblies on RF connector assembly. Use three 2-56 x 5/8 inch screws and lockwashers. Screws must be tightened firmly to insure proper bellows contact with the Type N center conductor.

**NOTE**

Printed circuit assembly must be positioned so it does not cover compensating screws.

---

- 5 Connect red and white wires from thermistor assembly to printed circuit assembly.
- 6 Connect thermistor mount to a Keysight model 431. Check for proper null and zero.
- 7 If desired, check SWR and efficiency. The Mount SWR has been adjusted at the factory to be about equal at 9 GHz and 10 GHz and less than 1.5. The adjustment is made with the 5/16-23 setscrew which is secured by a locknut. The setscrew should not be moved unless SWR is being calibrated. Efficiency may be checked by comparing to a known good mount.

**CAUTION**

To prevent pulling wires out of terminal connector, secure terminal shield with one 2-56 x 3/16 inch screw while making checks.

---

- 8 When any testing or recalibration is completed, secure terminal shield with three 2-56 x 3/16 inch screws. This completes the Installation Procedure.

## Recalibration

If recalibration of the mount is desired, the instrument may be sent to the factor for repair and recalibration. Any Keysight Technologies Sales and Service Office will arrange for such repair.

THIS PAGE HAS BEEN INTENTIONALLY LEFT BLANK.

Keysight 478A Thermistor Mount  
Operating and Service Manual

# A Appendix A

Introduction	46
Manual Changes	47

## Introduction

This appendix contains manual change instructions for backdating the manual for thermistor mounts with serial numbers lower than 79401.

### How to Use This Appendix

To adapt the manual to your instrument, refer to [Table A-1](#). Make all of the manual changes listed opposite your instrument's serial number. The manual changes should be performed in the sequence shown in the table. For example, Change B should be done before Change A.

If your instrument's serial number is higher than 79401 or not listed in [Table A-1](#), it may be documented in a separate MANUAL CHANGES supplement.

**Table A-1** Manual Changes by Serial Number

<b>Serial Number</b>	<b>Make Manual Changes</b>
65600 and below	B, A
65601 through 73300	B

# Manual Changes

## Change A

Replace [Figure 2-5](#), “Schematic Diagram of a Model 478A Thermistor Mount when Connected to a 431 Power Meter,” on page 25 with [Figure A-1](#).

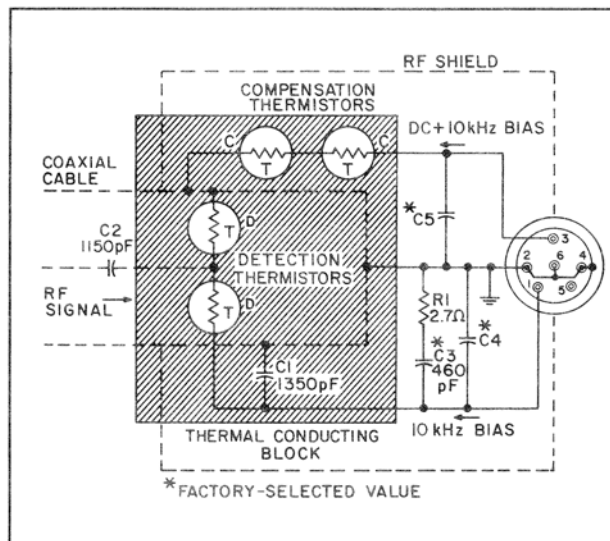

**Figure A-1** Schematic Diagram of a Model 478A Thermistor Mount when Connected to a 431 Power Meter. (P/O Change A)

Replace Figure 4-1, "Schematic Diagram of a Model 478A Thermistor Mount when Connected to a 432 Power Meter," on page 34 with Figure A-2.

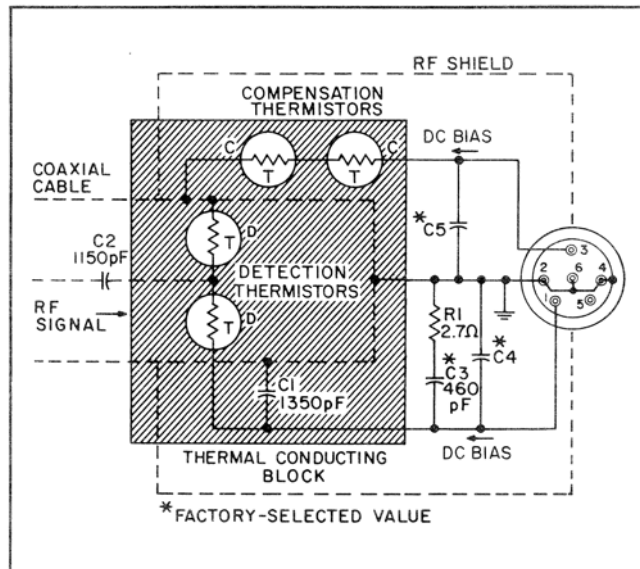

**Figure A-2** Schematic Diagram of a Model 478A Thermistor Mount when Connected to a 432 Power Meter. (P/O Change A)



Replace Figure 4-2, "Check on Model 478A Thermistor Resistance Match," on page 35 with Figure A-3.

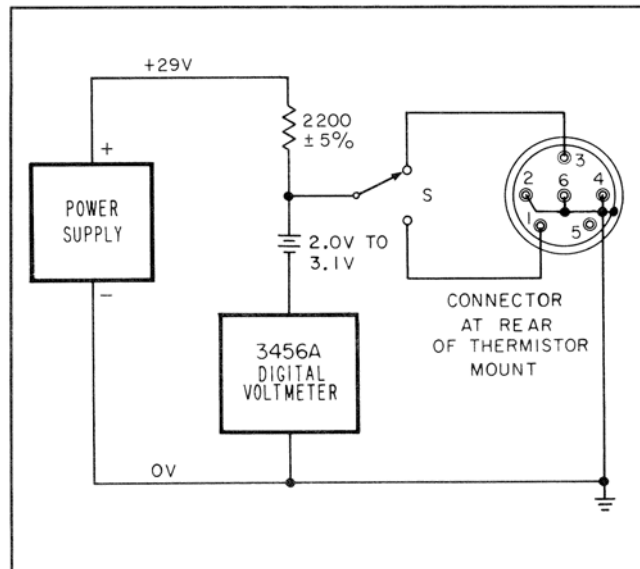

**Figure A-3** Check on Model 478A Thermistor Resistance Match (P/O Change A)

Change B

Replace Figure 2-4, "Source Impedance Shunting One RF Thermistor Mount," on page 23 with Figure A-4.

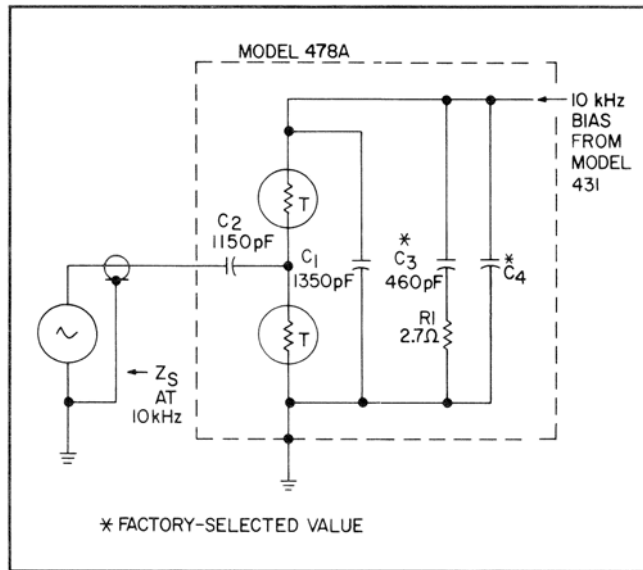

**Figure A-4** Source Impedance Shunting One RF Thermistor Mount (P/O Change B)

Replace Figure 2-5, "Schematic Diagram of a Model 478A Thermistor Mount when Connected to a 431 Power Meter," on page 25 with Figure A-5.

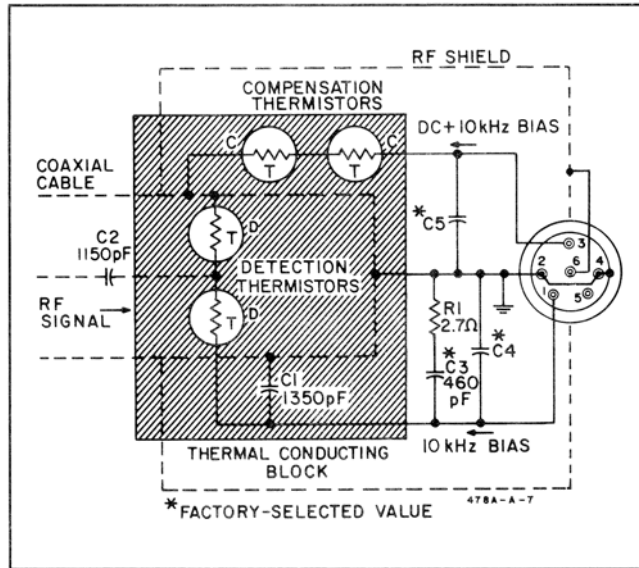

**Figure A-5** Schematic Diagram of a Model 478A Thermistor Mount when Connected to a 431 Power Meter. (P/O Change B)

Replace Figure 4-1, "Schematic Diagram of a Model 478A Thermistor Mount when Connected to a 432 Power Meter," on page 34 with Figure A-6.

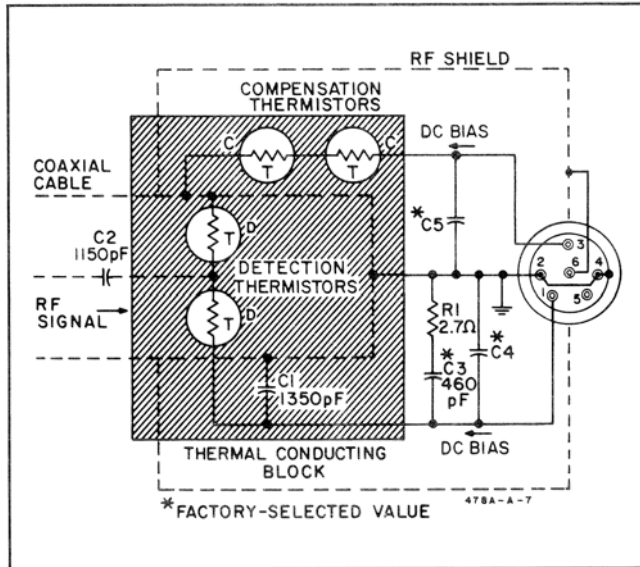

**Figure A-6** Schematic Diagram of a Model 478A Thermistor Mount when Connected to a 432 Power Meter. (P/O Change B)

Replace Figure 4-3, "Thermistor Compensation," on page 37 with Figure A-7.

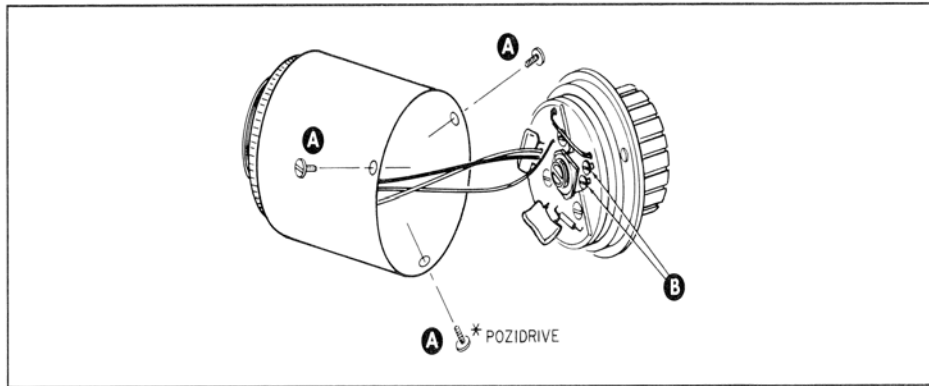

**Figure A-7** Thermistor Compensation (P/O Change B)

Replace Figure 4-4, "Model 478A Thermistor Mount Assembly," on page 41 with Figure A-8.

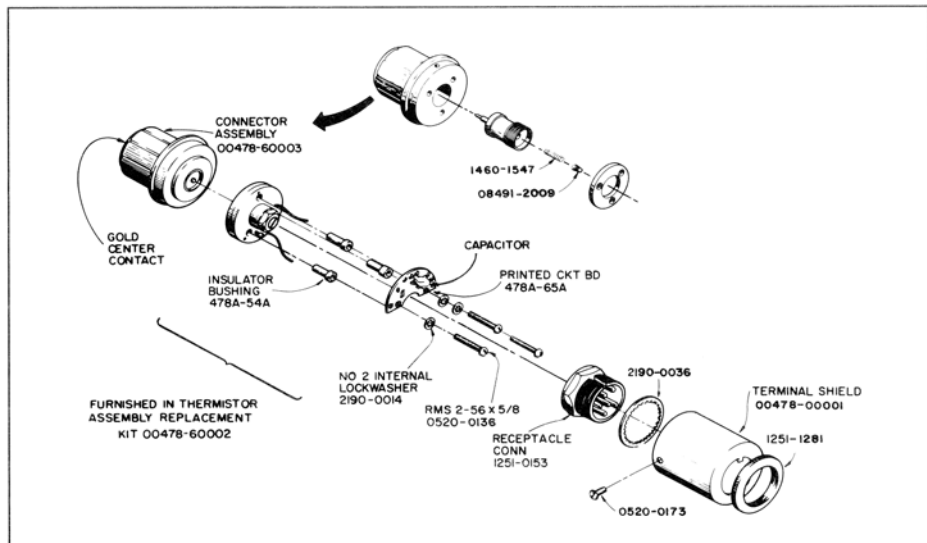

**Figure A-8** Model 478A Thermistor Mount Assembly (P/O Change B)

Replace Figure 4-5, "Keysight Model 478A Printed Circuit Assy Wiring," on page 42 with Figure A-9.

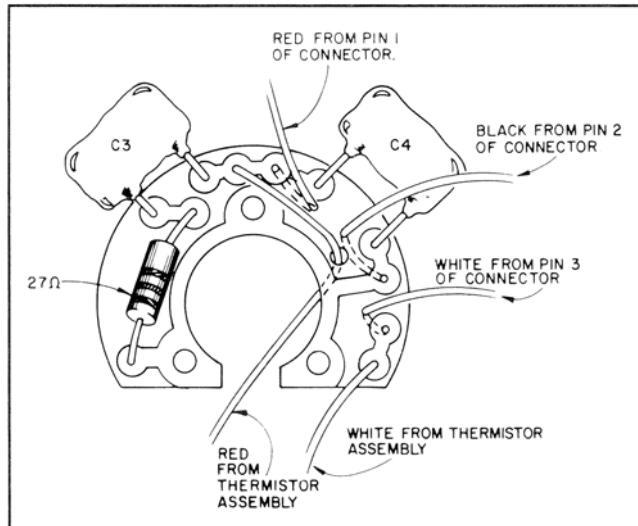

**Figure A-9** Keysight Model 478A Printed Circuit Assembly Wiring (P/O Change B)



This information is subject to change without notice. Always refer to the Keysight website for the latest revision.

© Keysight Technologies 2008 - 2020  
Edition 3, January 23, 2020

Printed in Malaysia



00478-90021

[www.keysight.com](http://www.keysight.com)